

# NanoPi A64

Revision

1610 , First Release



NanoPi-A64		
Size A3	Document Number Title	Rev 1610
Date:	Thursday, December 15, 2016	Sheet 1 of 15

# BLOCK DIAGRAM

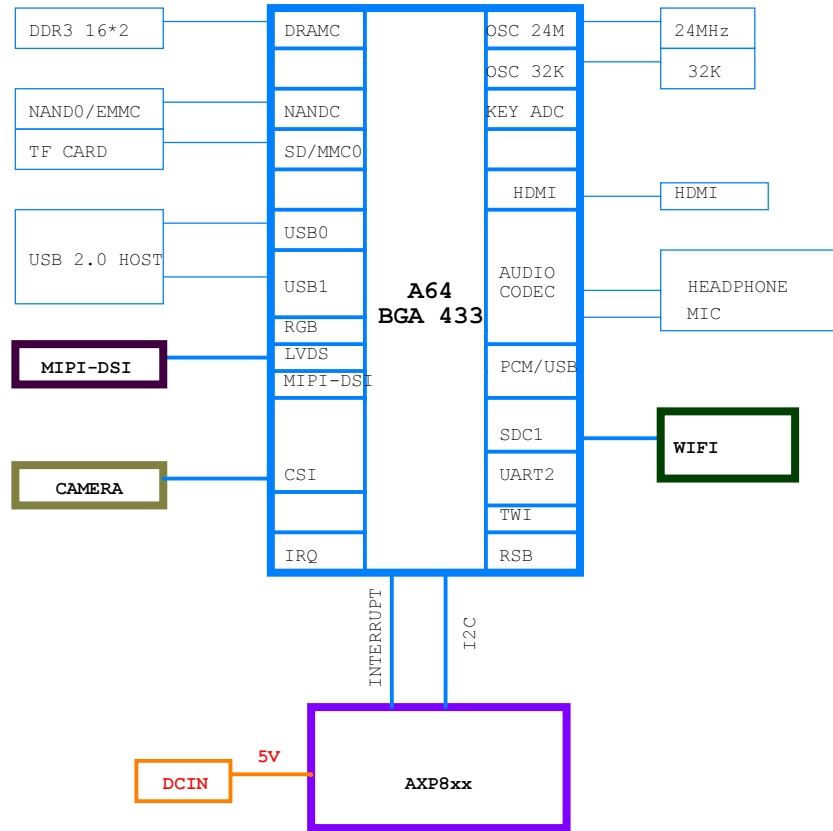

# POWER TREE

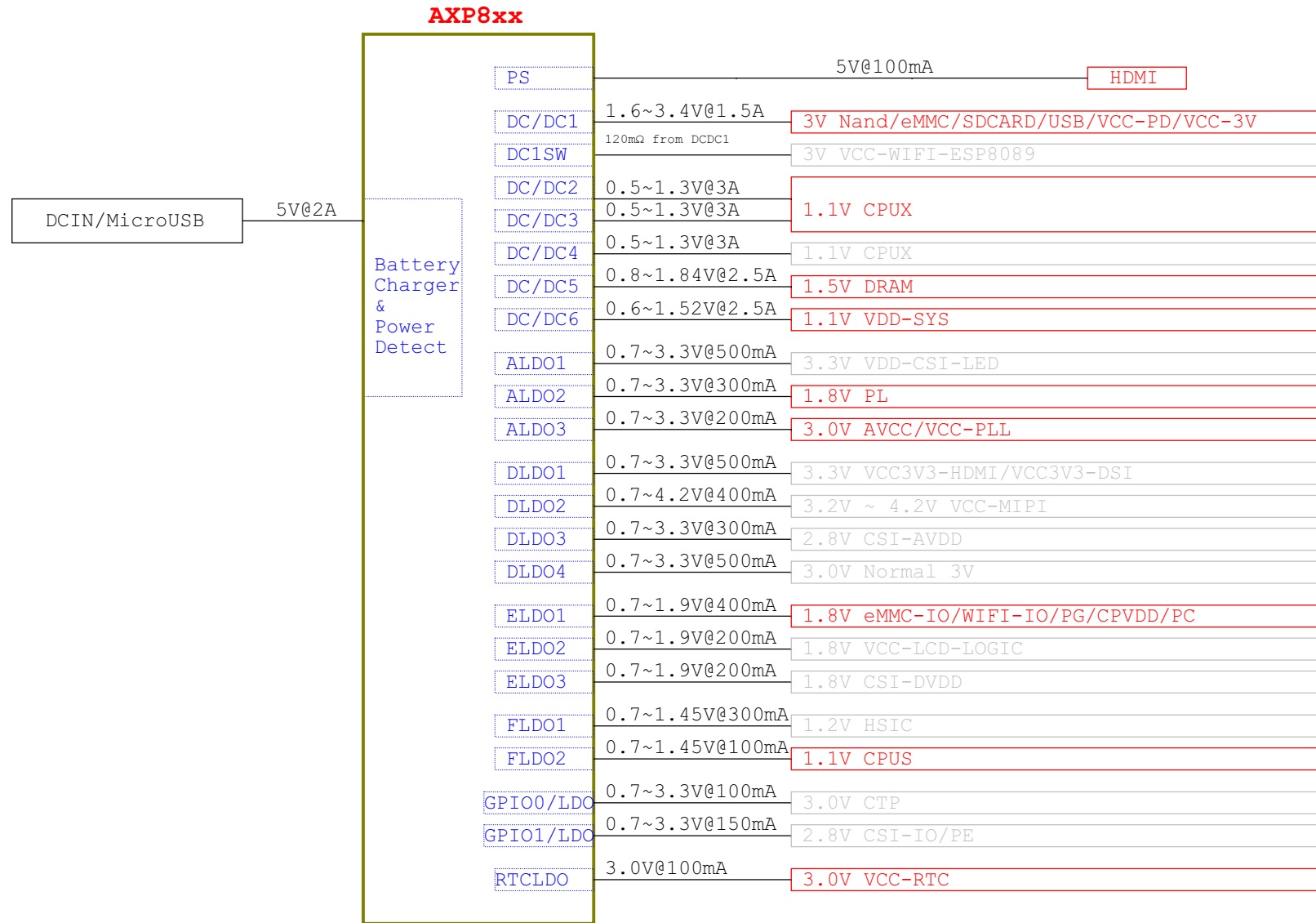

灰色：上电默认关  
红色：上电默认开



# DDR3

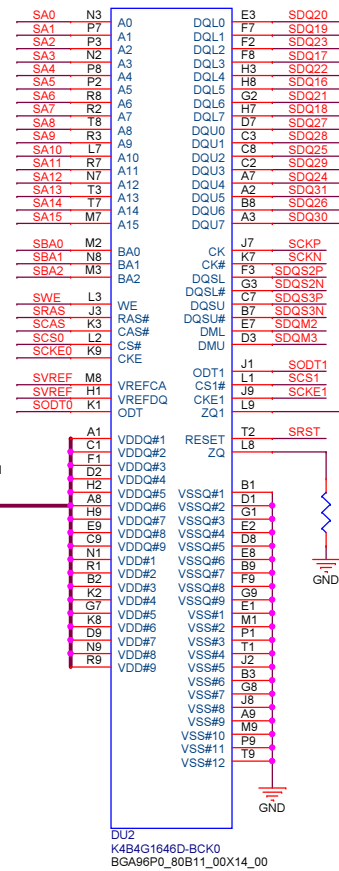
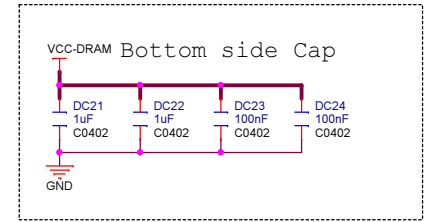
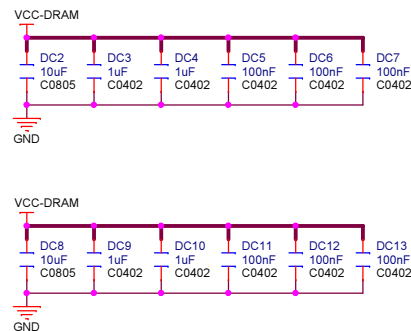
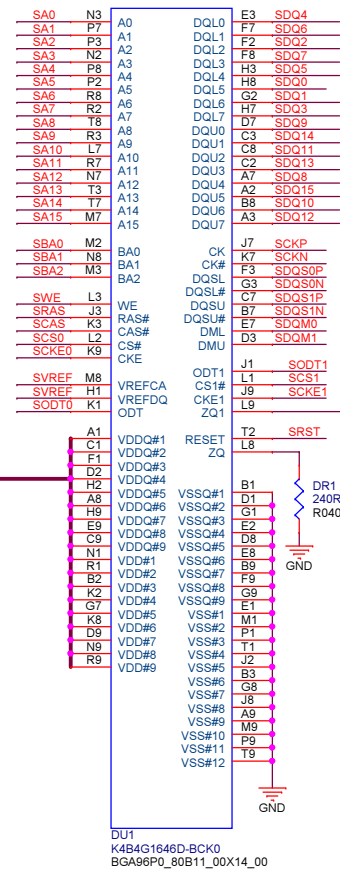
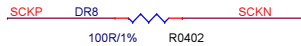
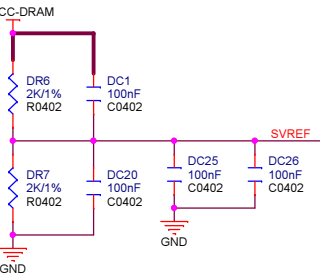
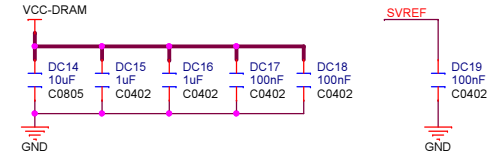
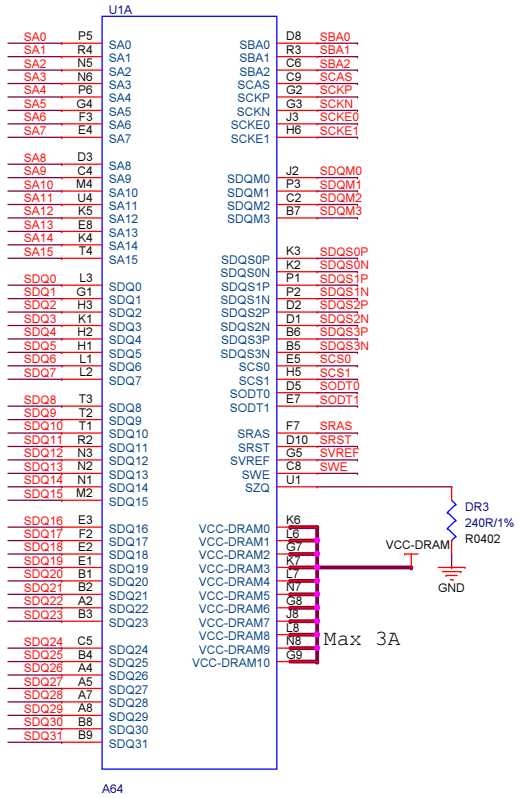

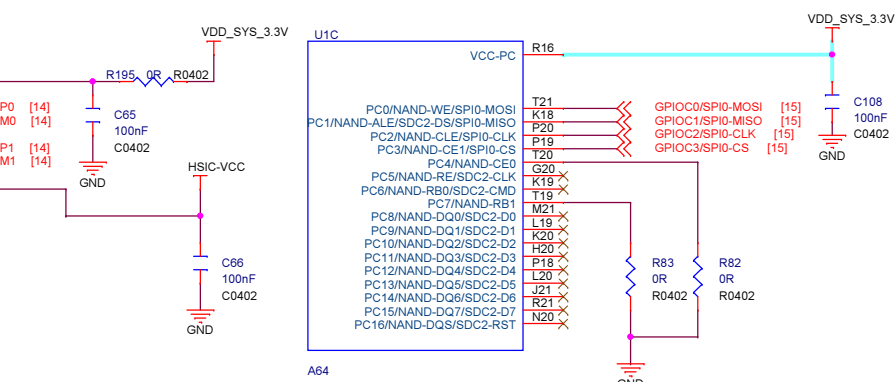
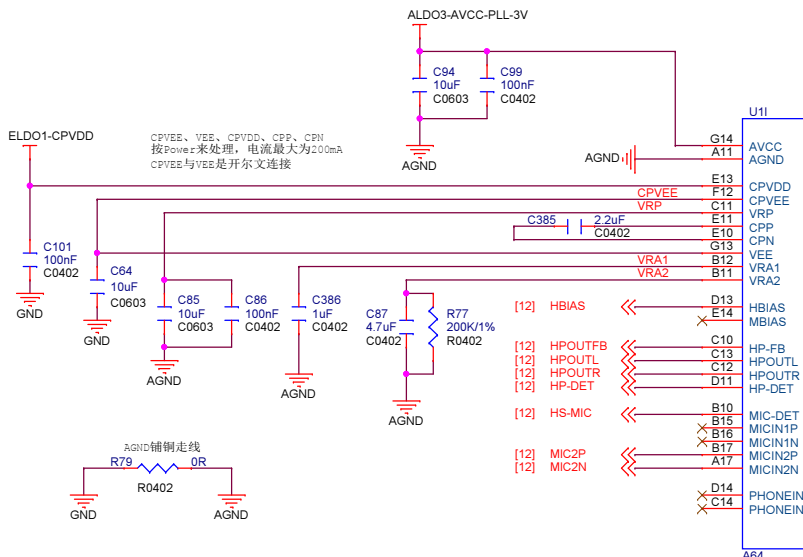
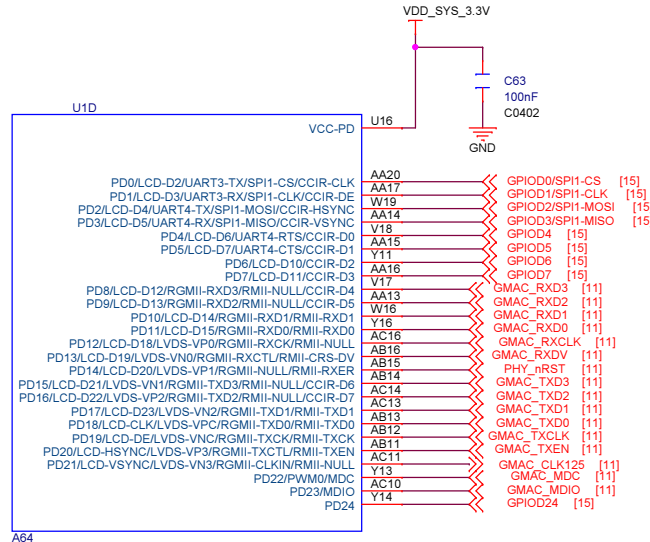
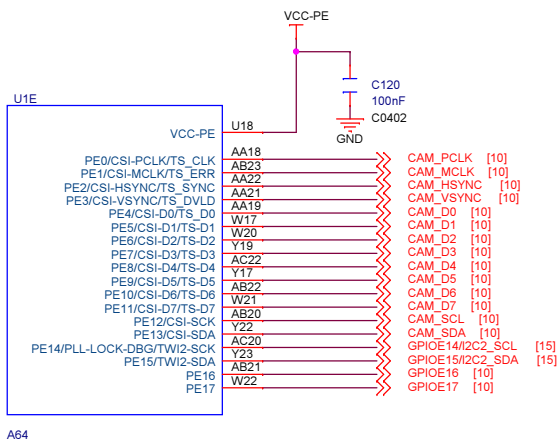
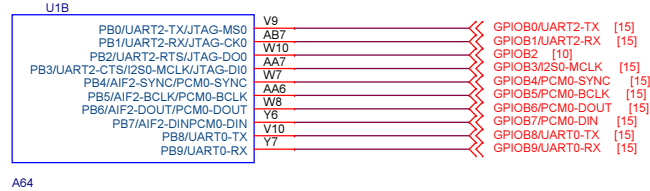
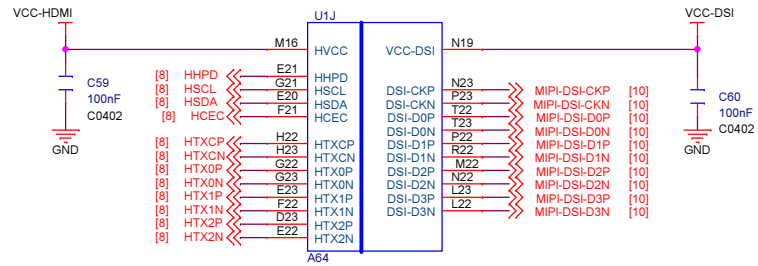

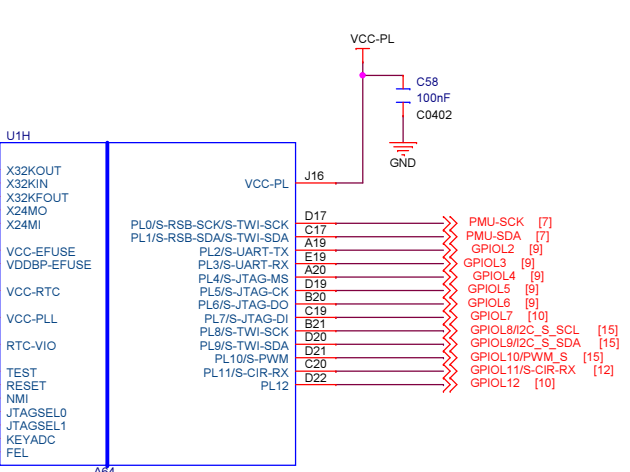
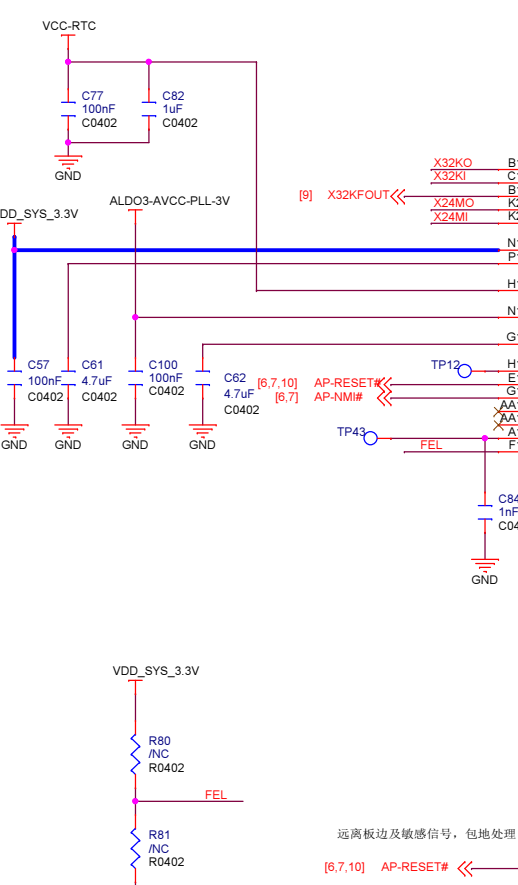
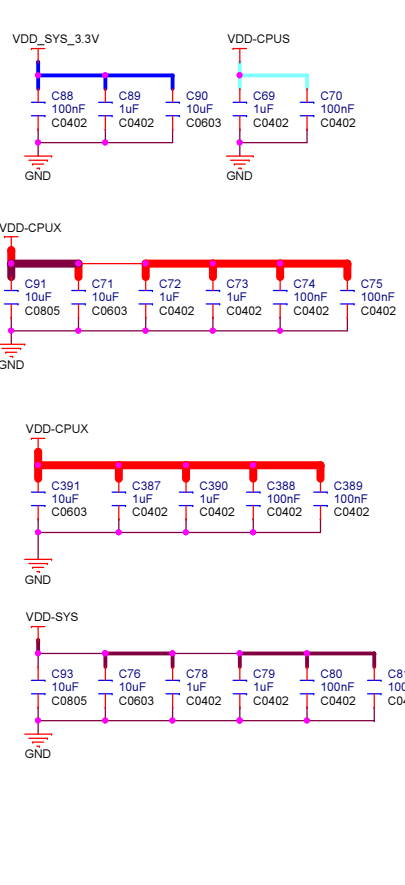
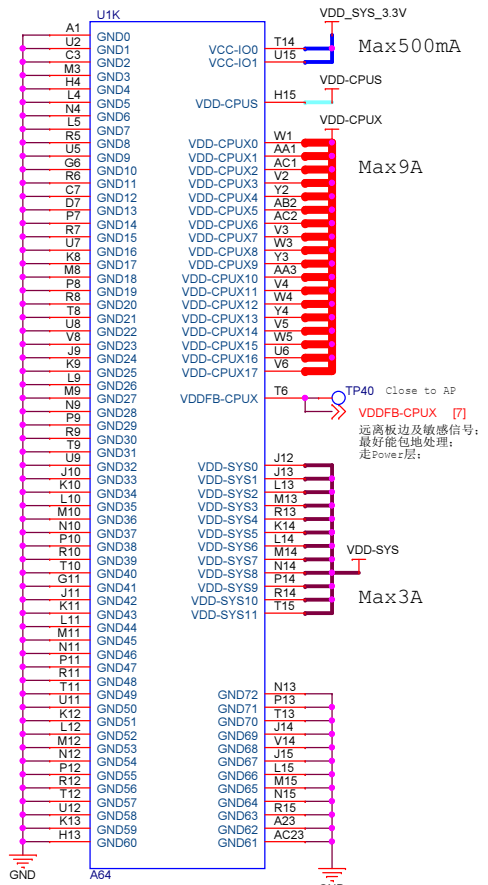

OSC-RTC

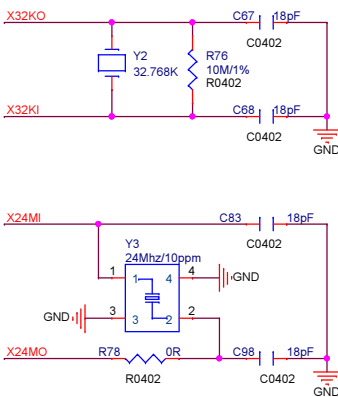

远离板边及敏感信号，包地处理

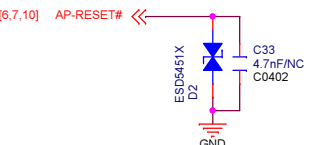

远离板边及敏感信号，包地处理

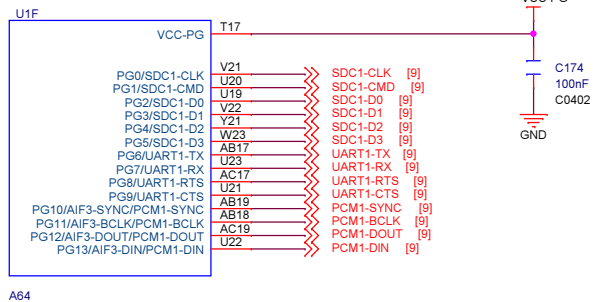
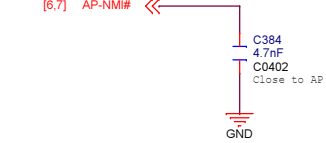

# POWER

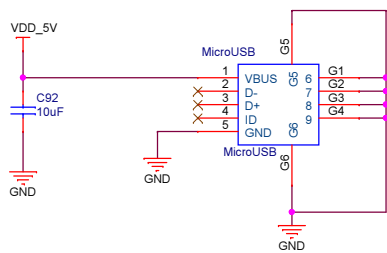
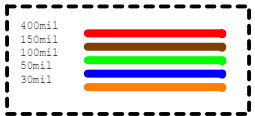
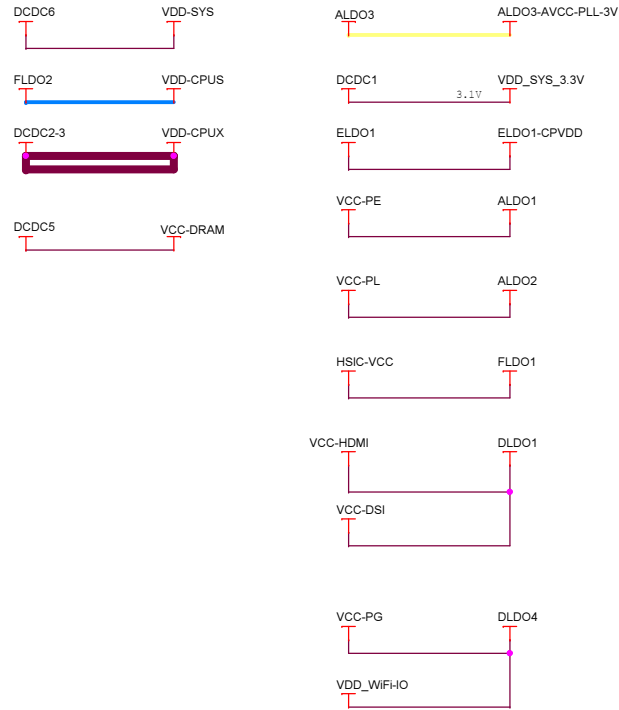

# PMIC

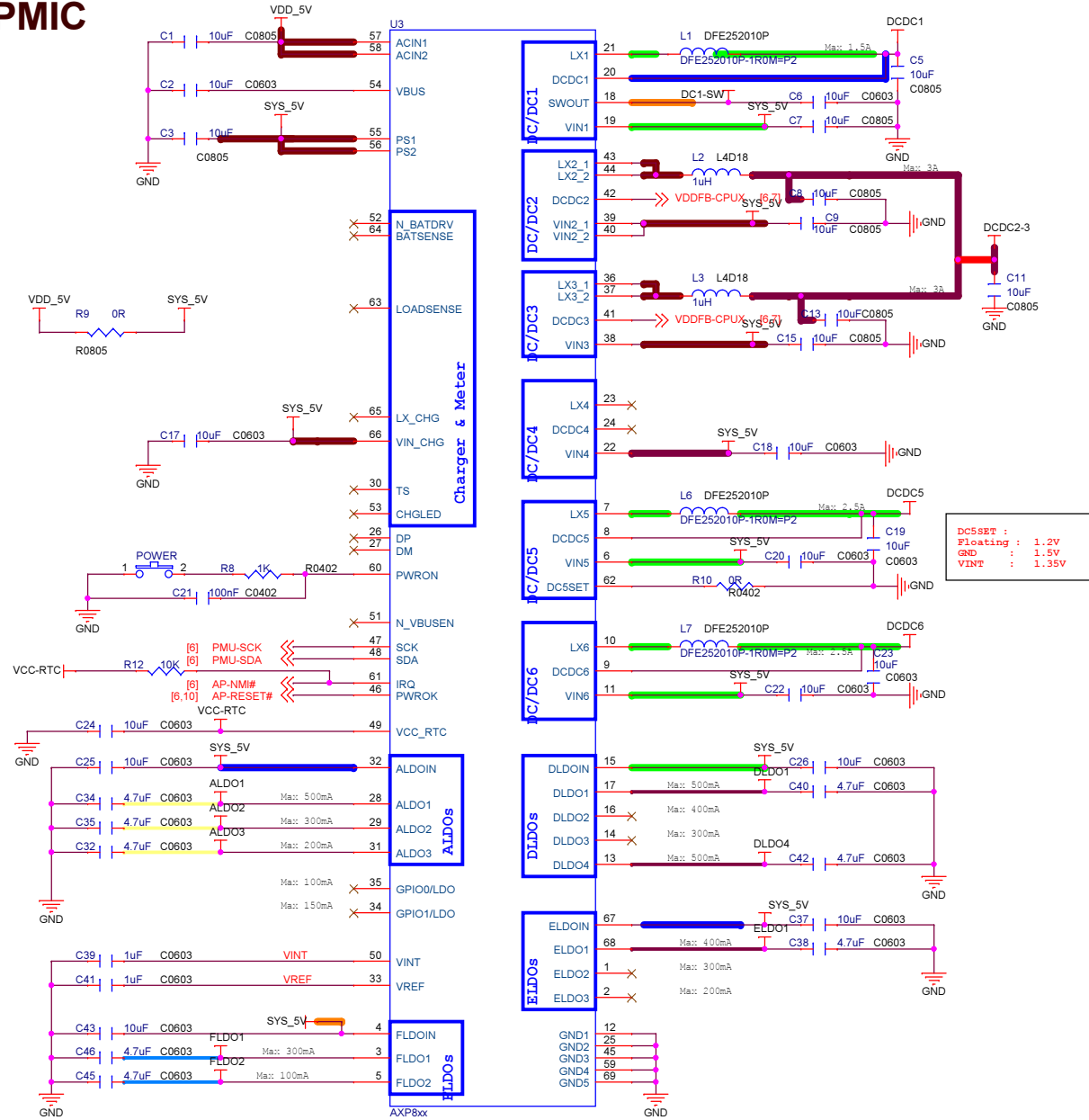

# HDMI

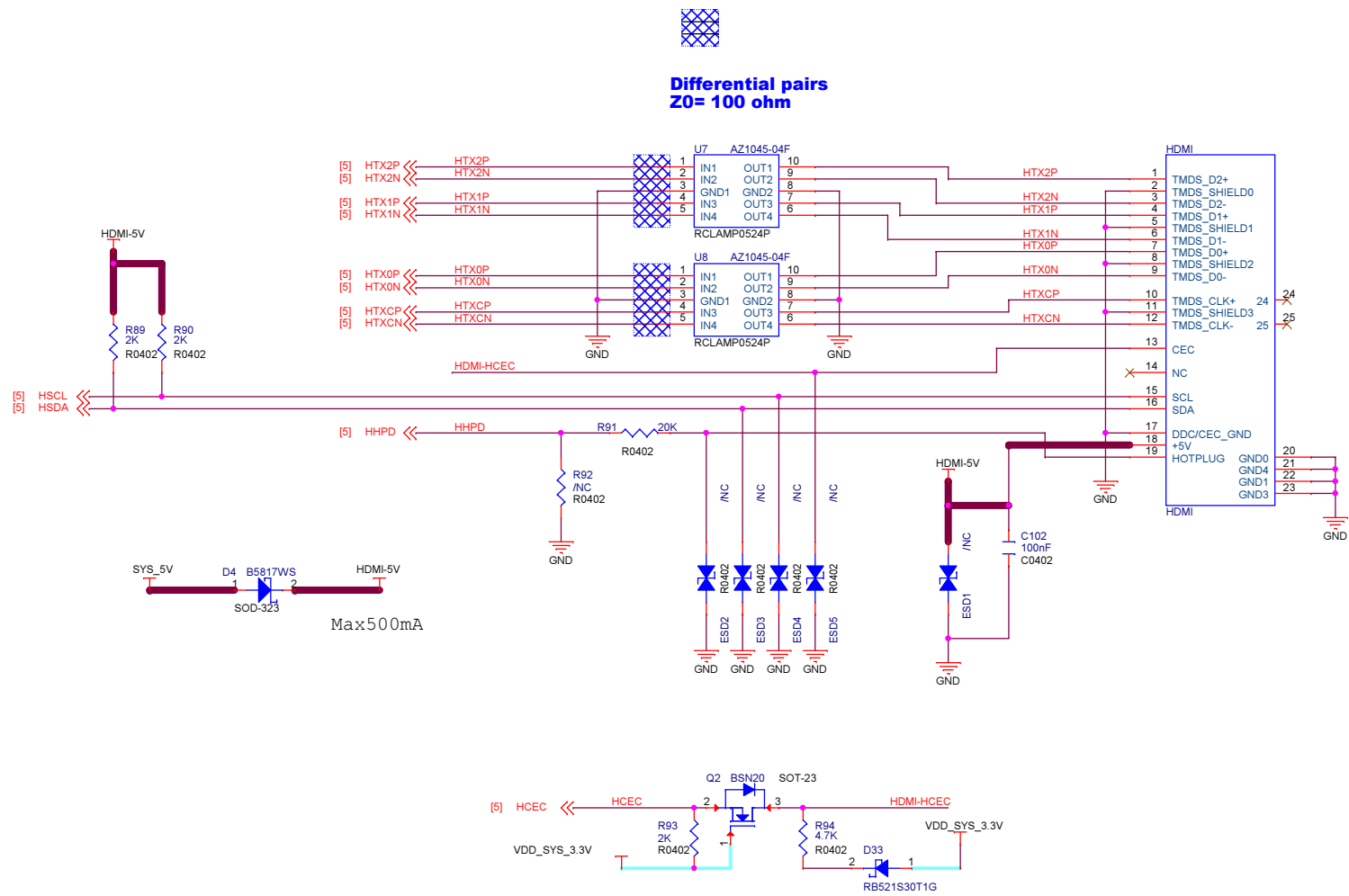



# Wi-Fi

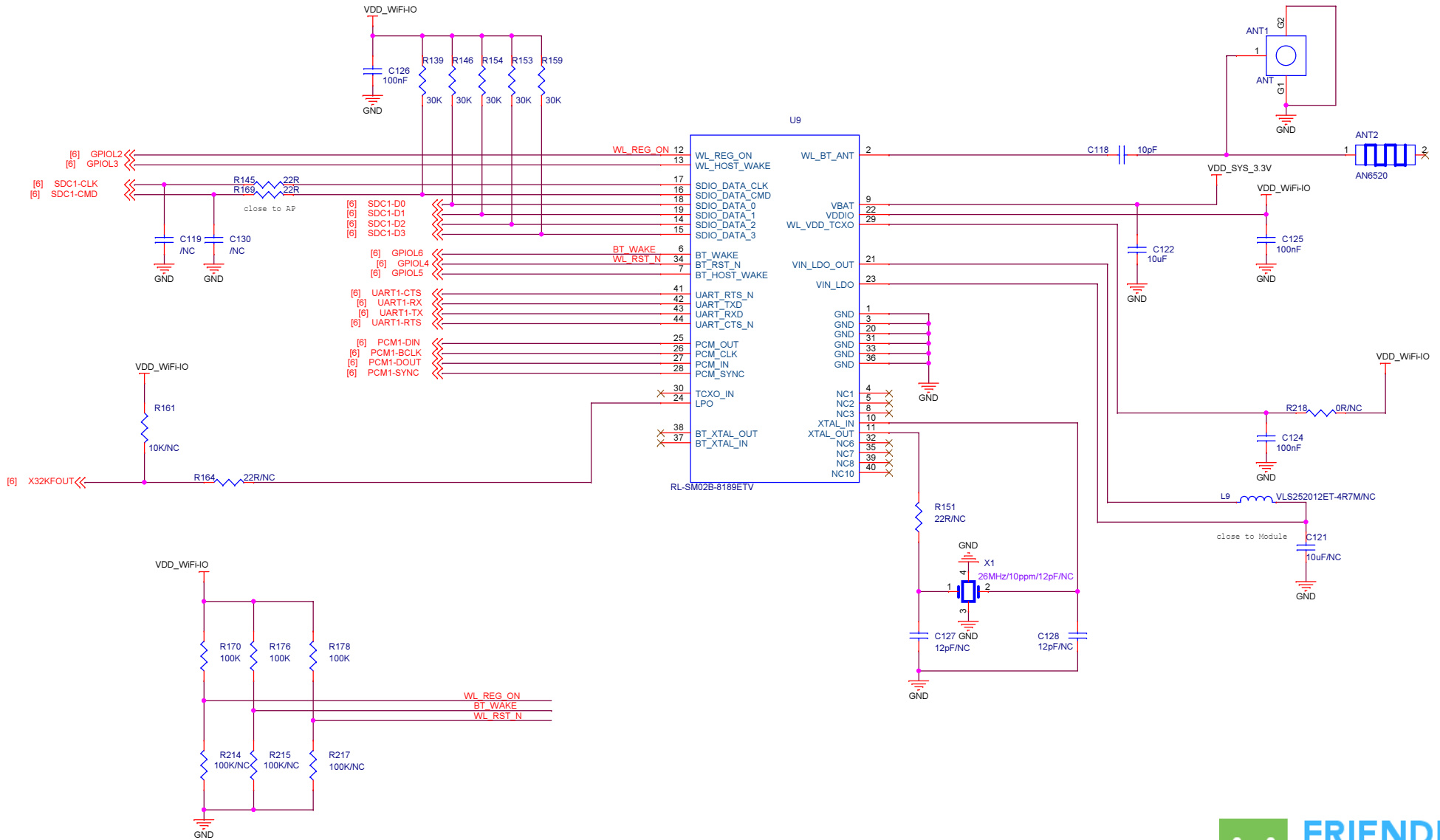

# Video Interface

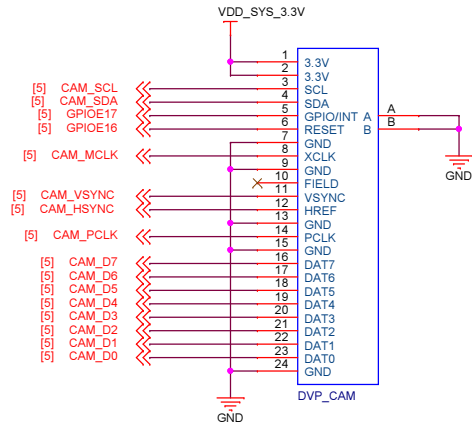

Camera Interface

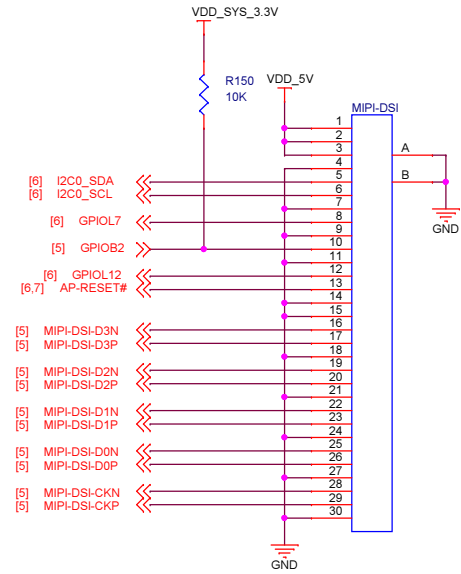

Display Interface



# 10/100/1000M Ethernet

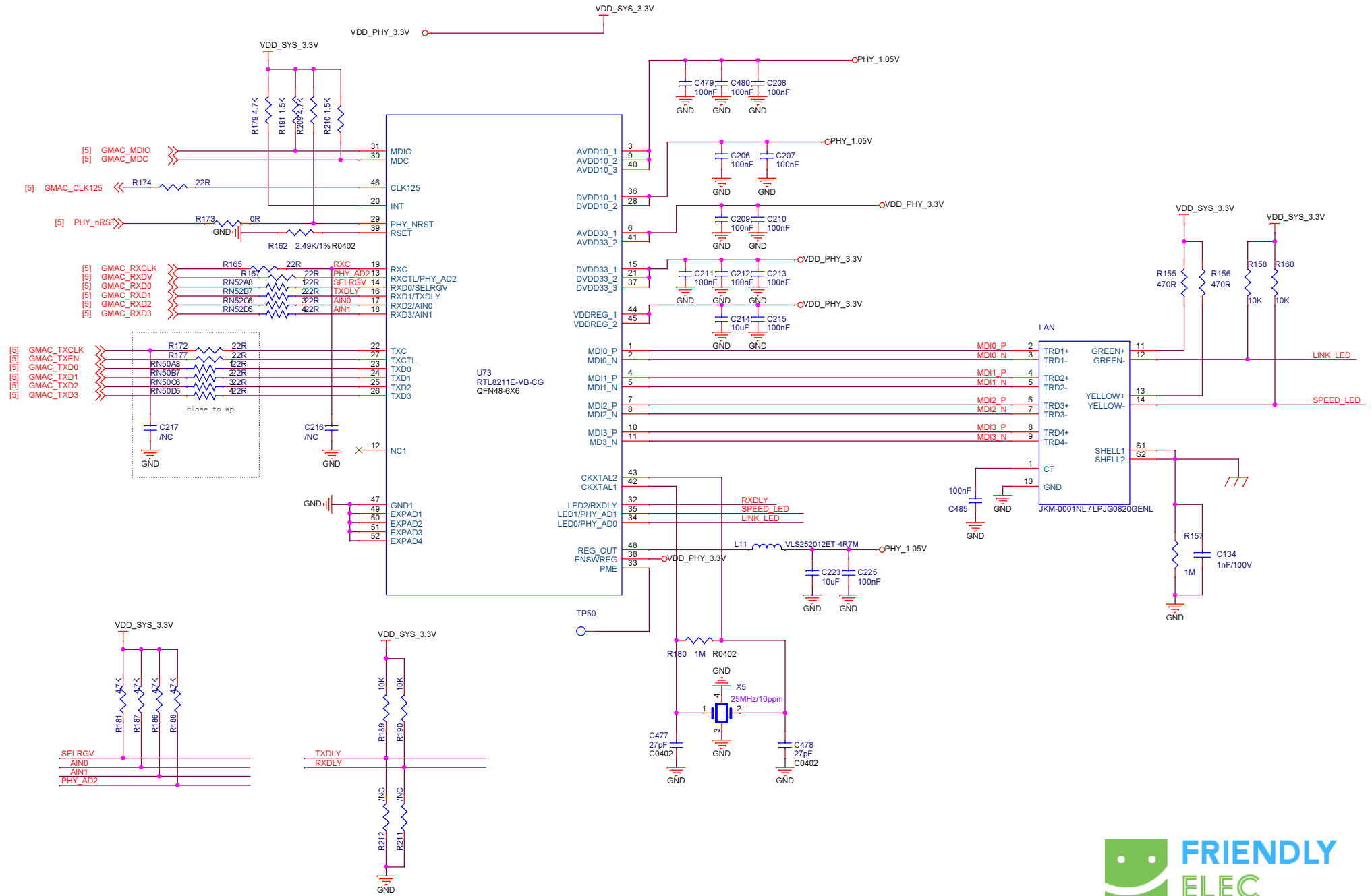

# HP\_JACK

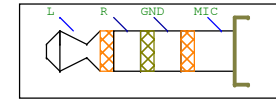
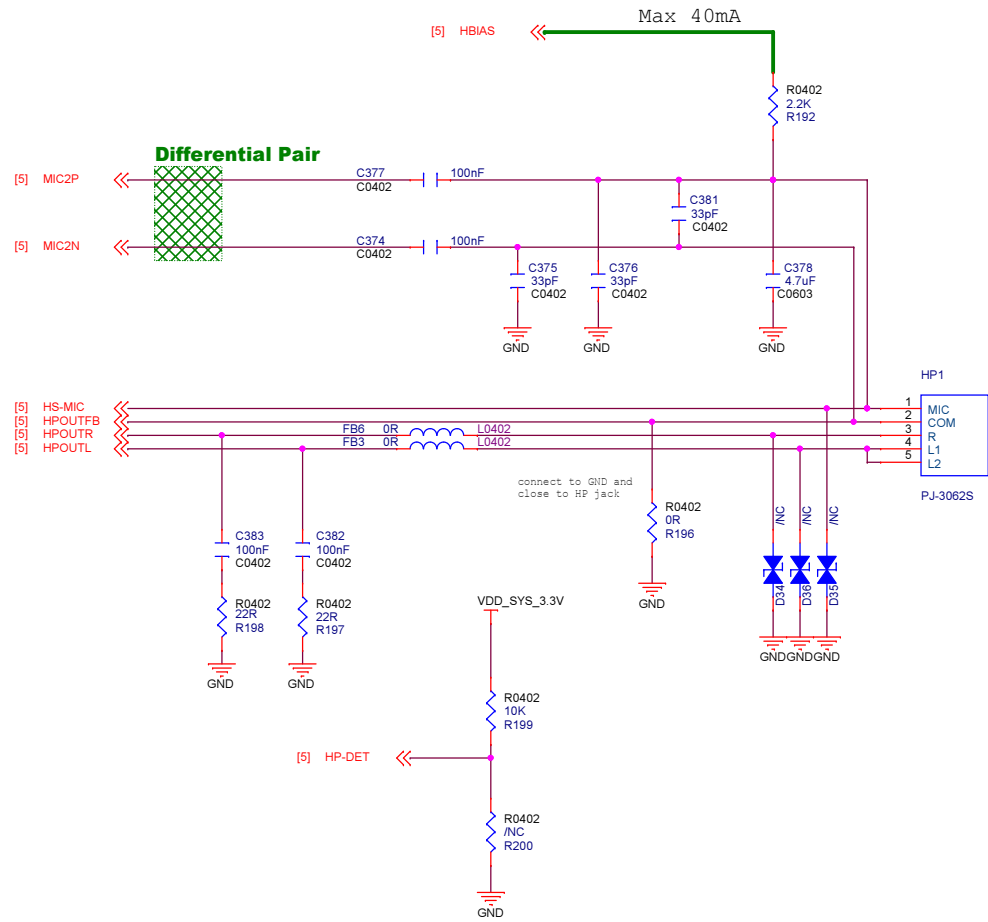

iPhone,SAMSUNG: L+R+G+M

# IR Reciver

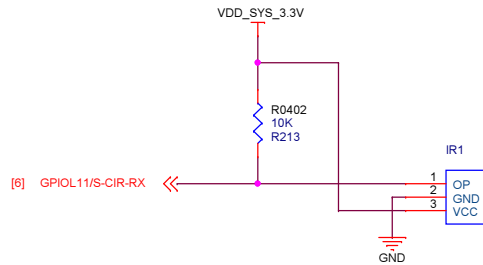

# MicroSD/USB

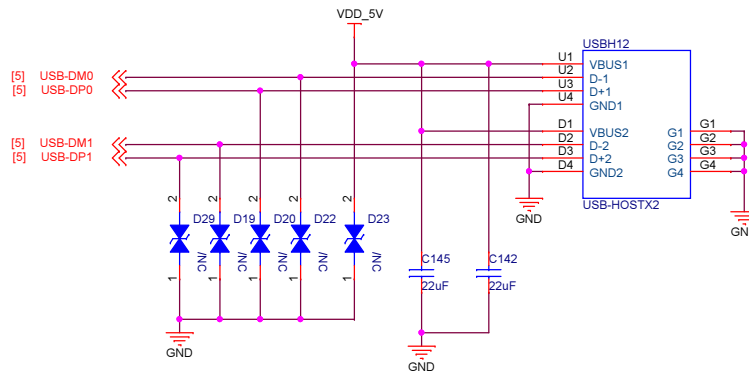
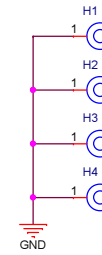
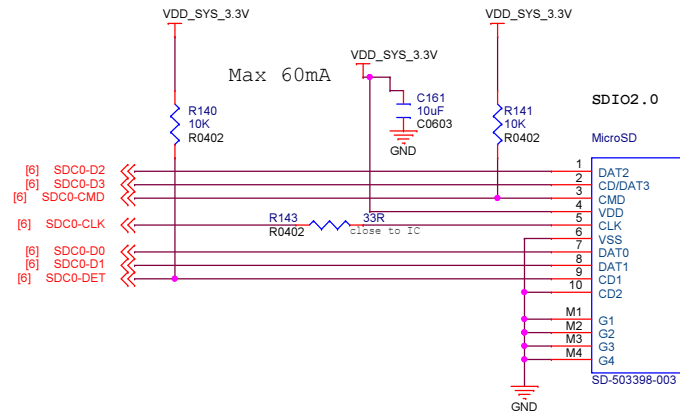

# GPIO/I2S

