

NanoPi M2A/M3

Revision

1604 , First Release

FRIENDLYARM

NanoPi M2A/M3		
Size	Document Number	Rev
A3	01.Title	1604
Date:	Wednesday, May 18, 2016	Sheet 1 of 15

PMIC

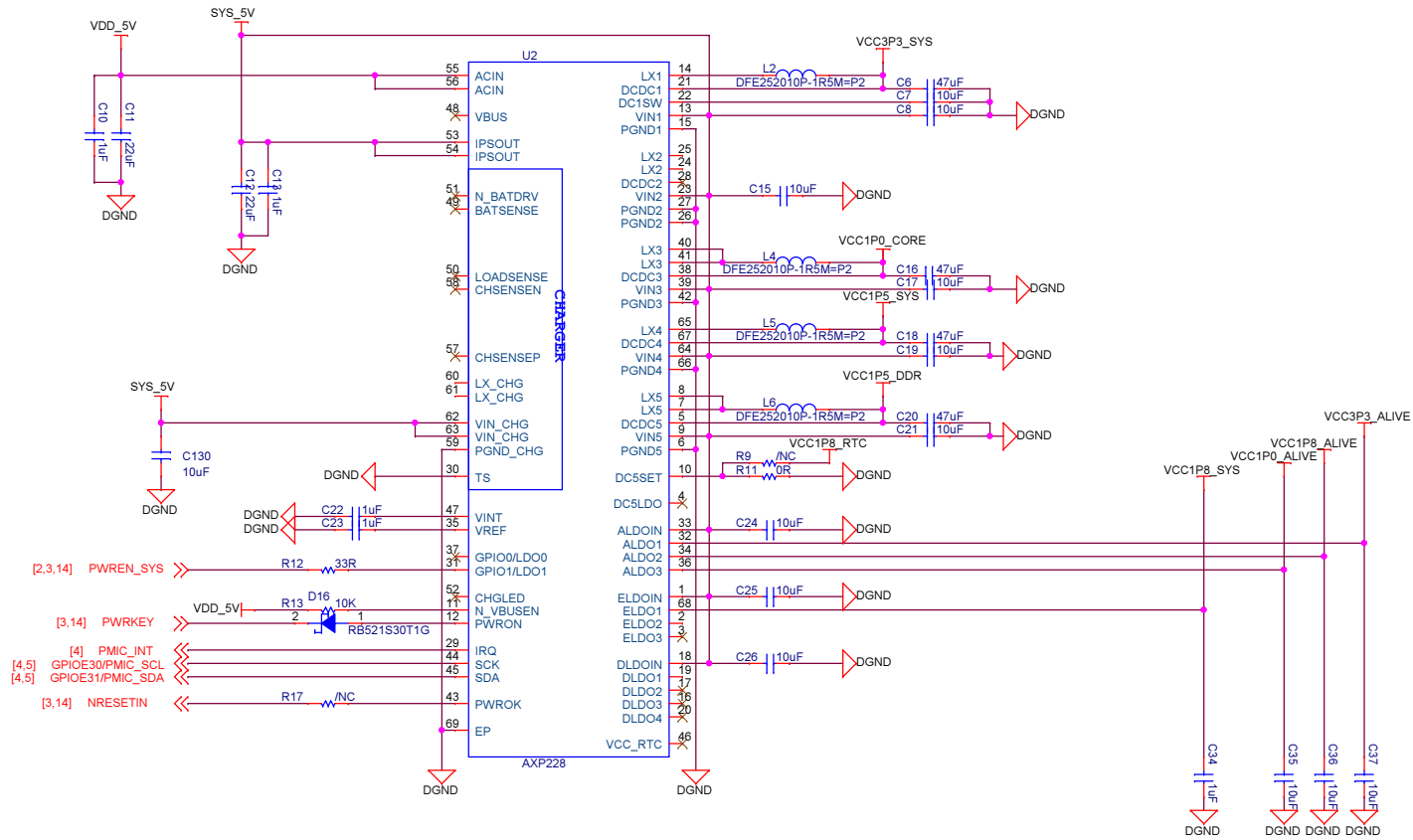

VDD_ARM

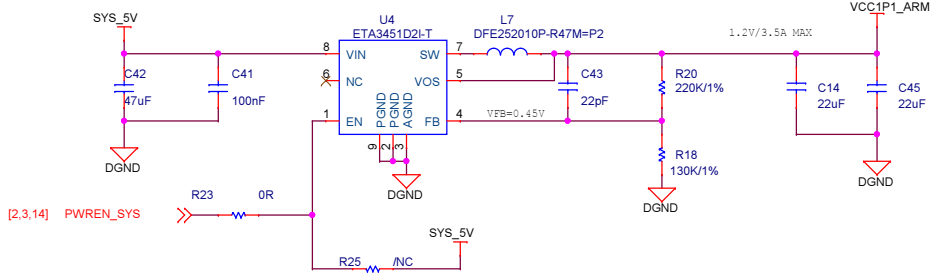

RTC Power

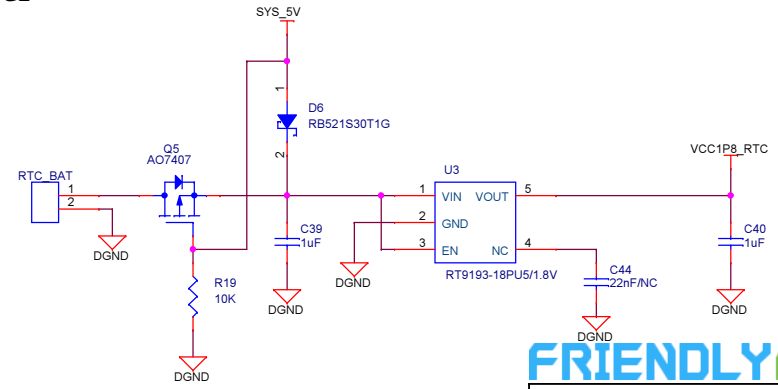

NanoPi M2A/M3		
Size A3	Document Number 02.PMIC	Rev 1604
Date: Wednesday, May 18, 2016	Sheet 2	of 15

System Reset, Clocks

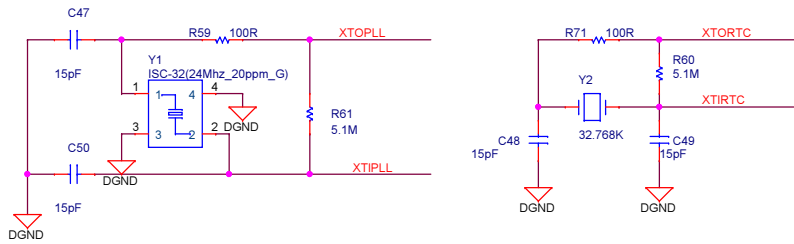
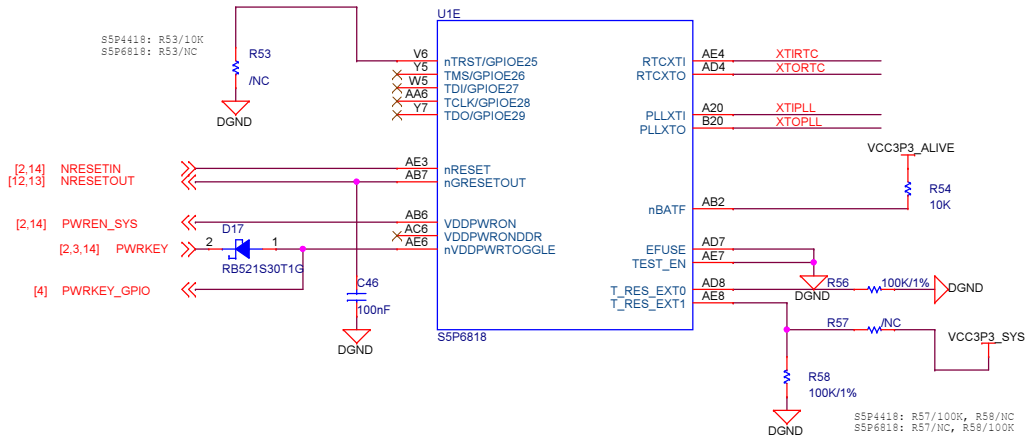

Boot Mode Config

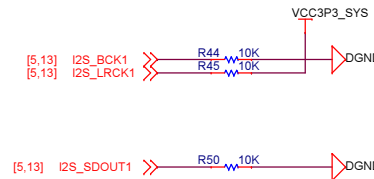
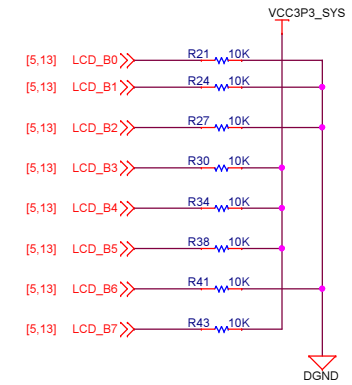

BOOT MODE OPTION

	eMMC	SPI	USB	NAND
SD0	HIGH	LOW	LOW	HIGH
SD1	LOW	LOW	HIGH	HIGH
SD2	HIGH	HIGH	HIGH	HIGH
SD4	LOW	HIGH		
SD5	LOW	LOW		

Boot media port select (SPI, eMMC)

	CH0	CH1	CH2
SD3	LOW	HIGH	LOW
CAM1_D3	LOW	LOW	HIGH

Sleep Detect

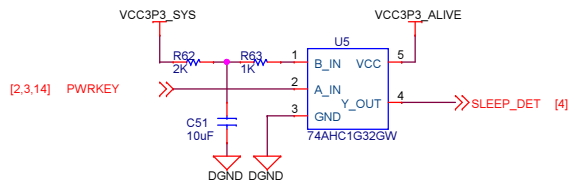

PCB Version

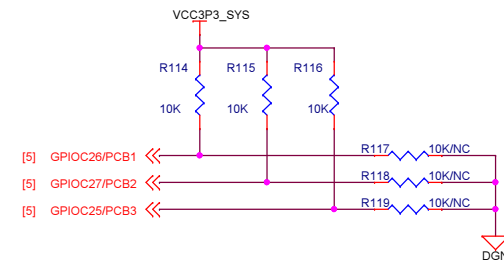

FRIENDLYARM

NanoPi M2A/M3

Size A3	Document Number 03.AP System Control	Rev 1604
Date: Wednesday, May 18, 2016	Sheet 3 of 15	

AP Peripherals

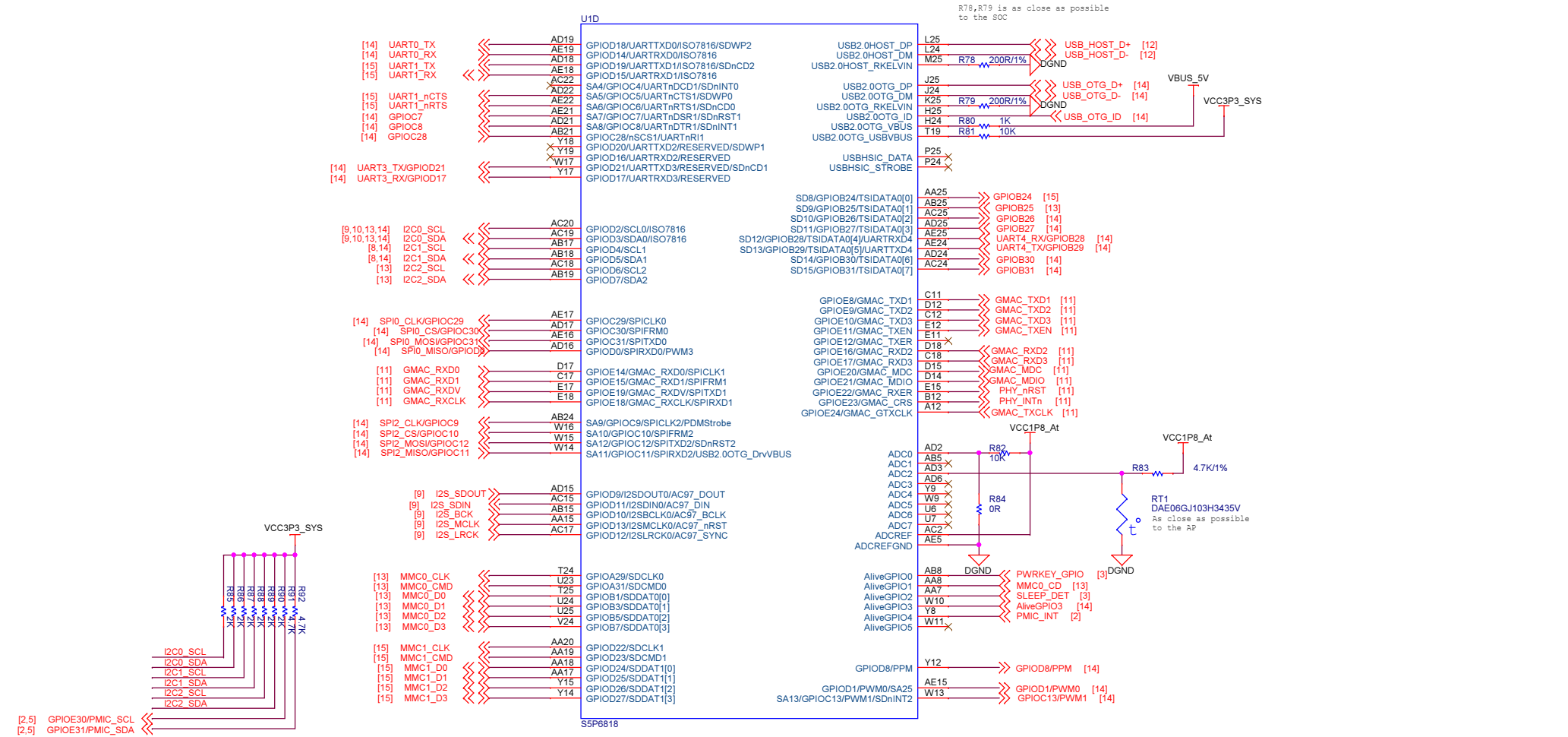

I2C CH0 : Camera
 I2C CH1 : HDMI EDID
 I2C CH2 : Touch
 PMIC_I2C : PMIC



AP VIP&Display

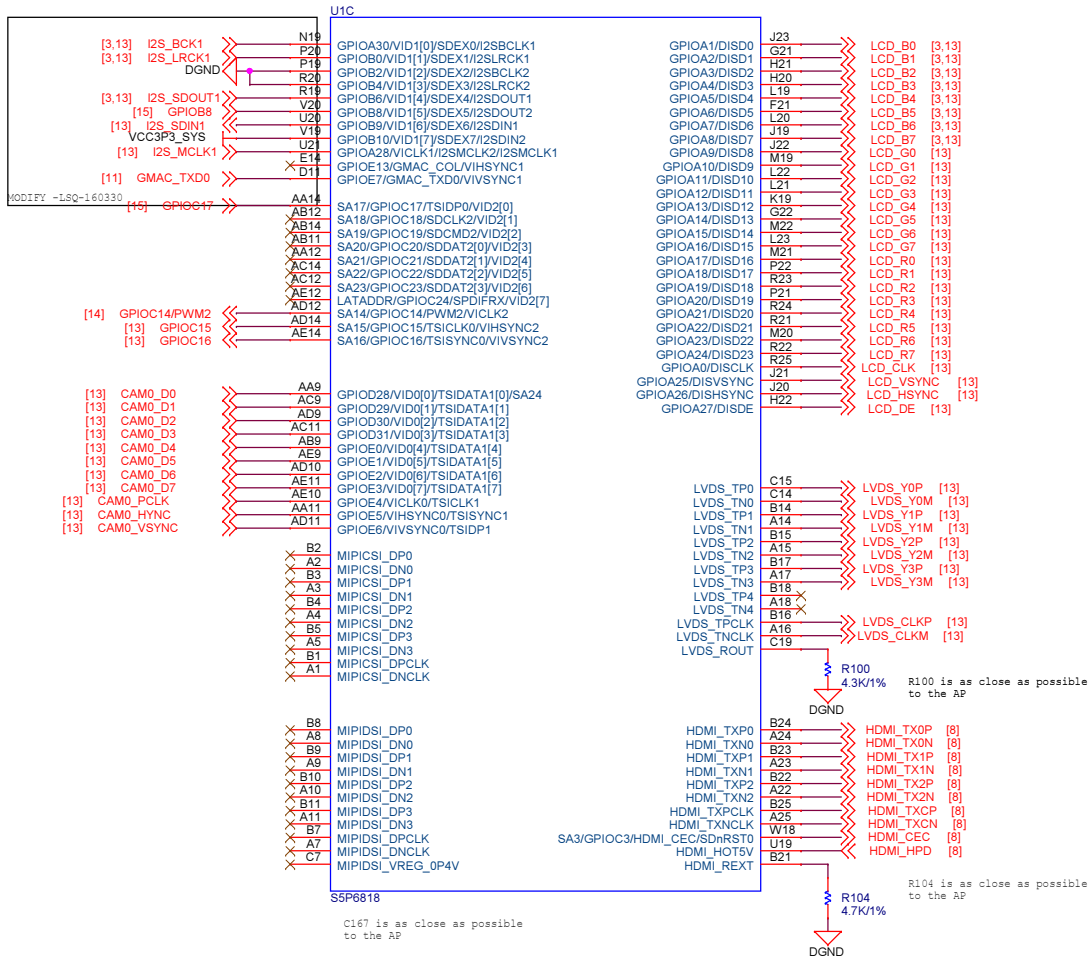

Reserved Function

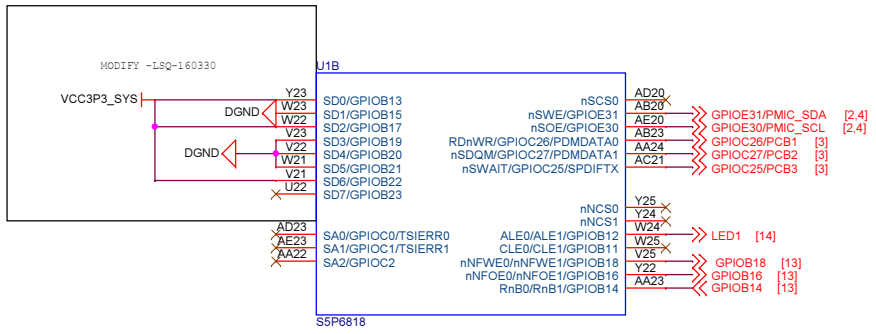
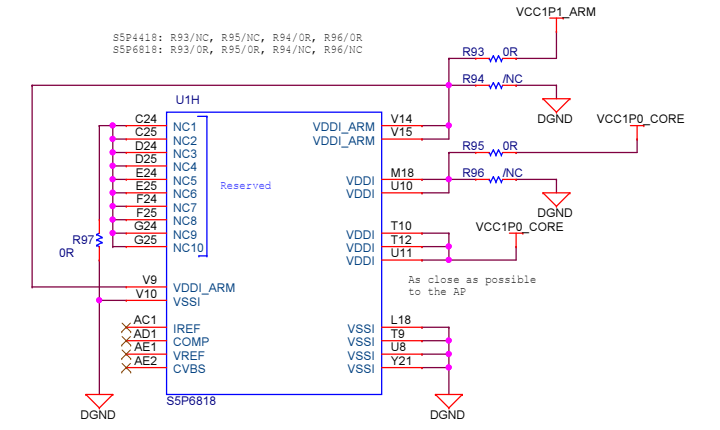

NanoPi M2A/M3		
Size A3	Document Number 05.AP VIP&Display	Rev 1604
Date: Wednesday, May 18, 2016	Sheet 5	of 15

AP Power

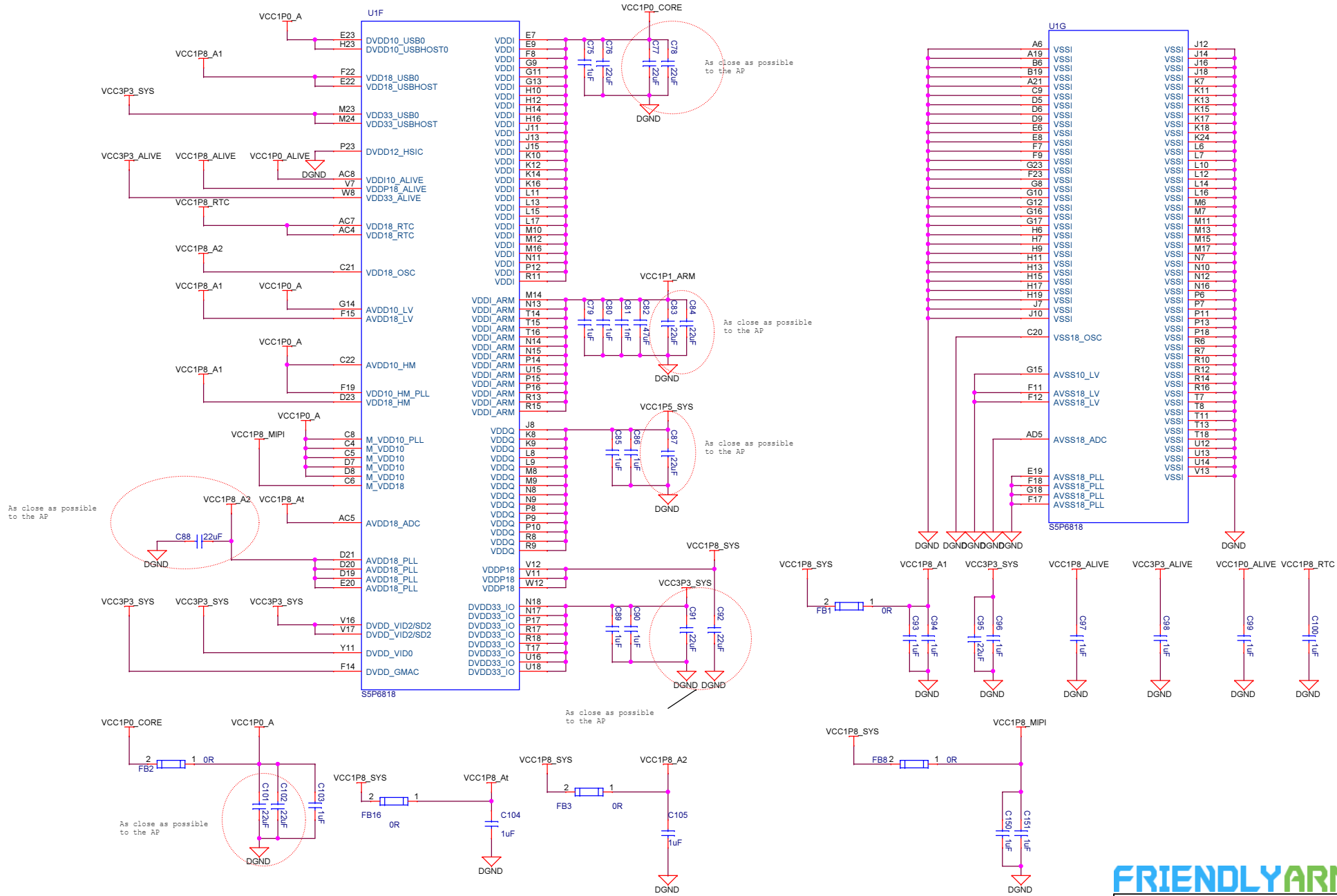

DDR3

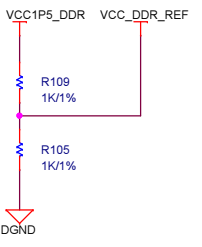
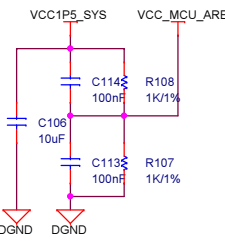
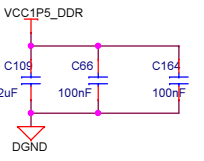
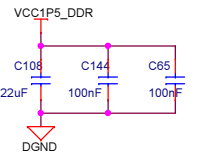
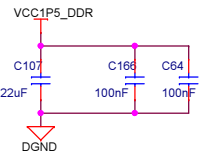
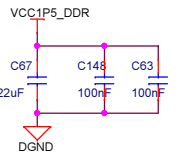
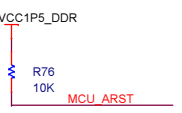
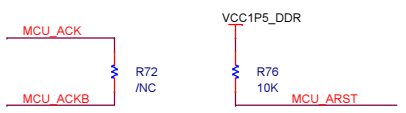
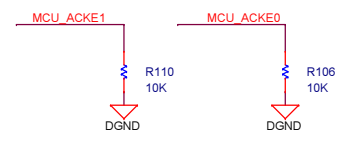
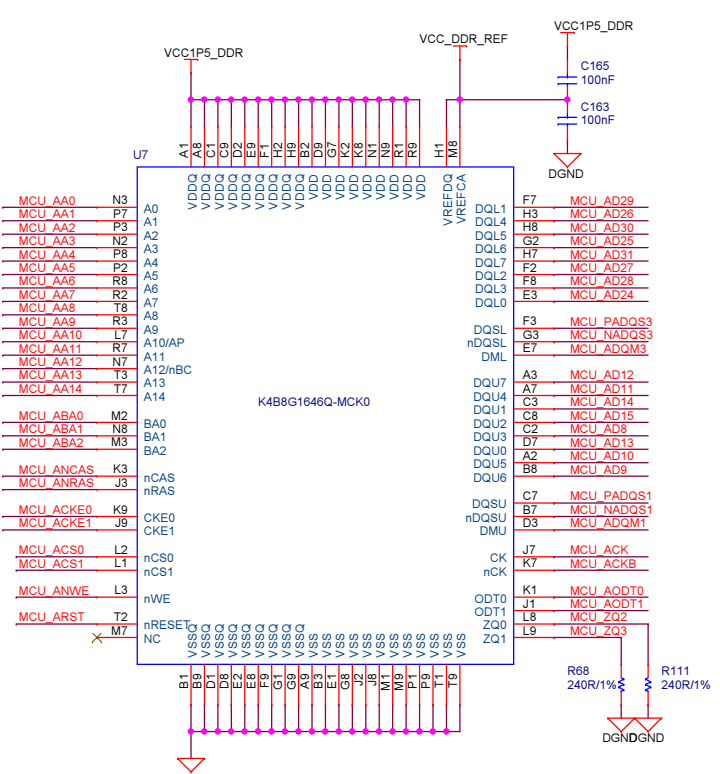
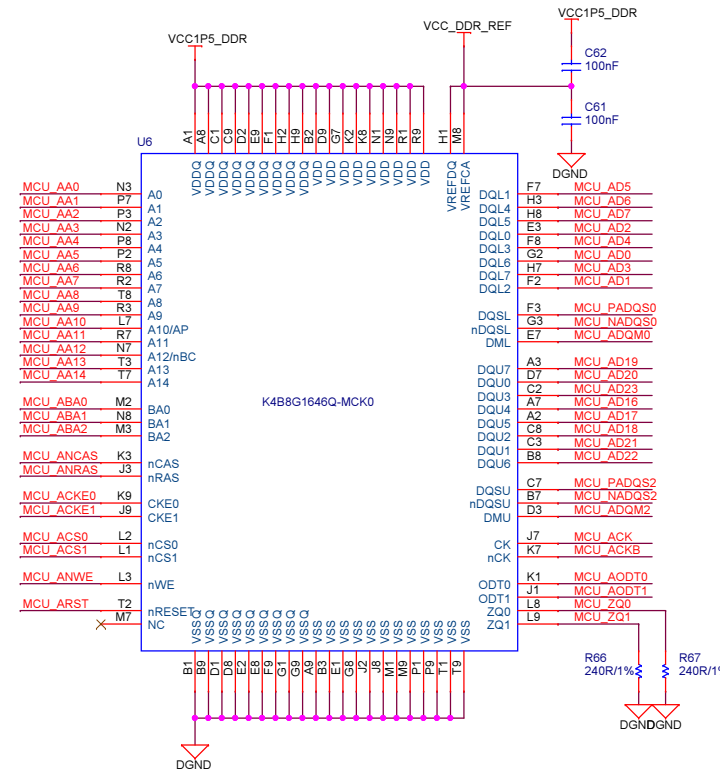
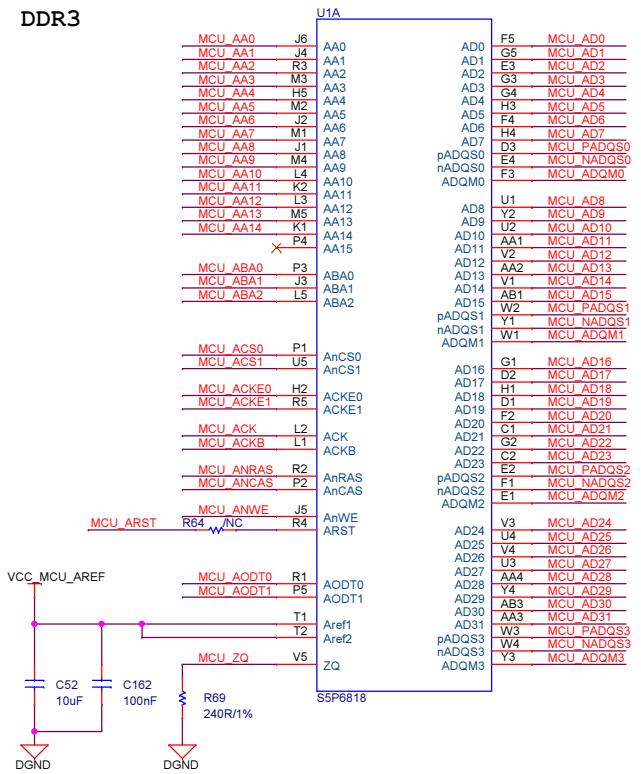

HDMI

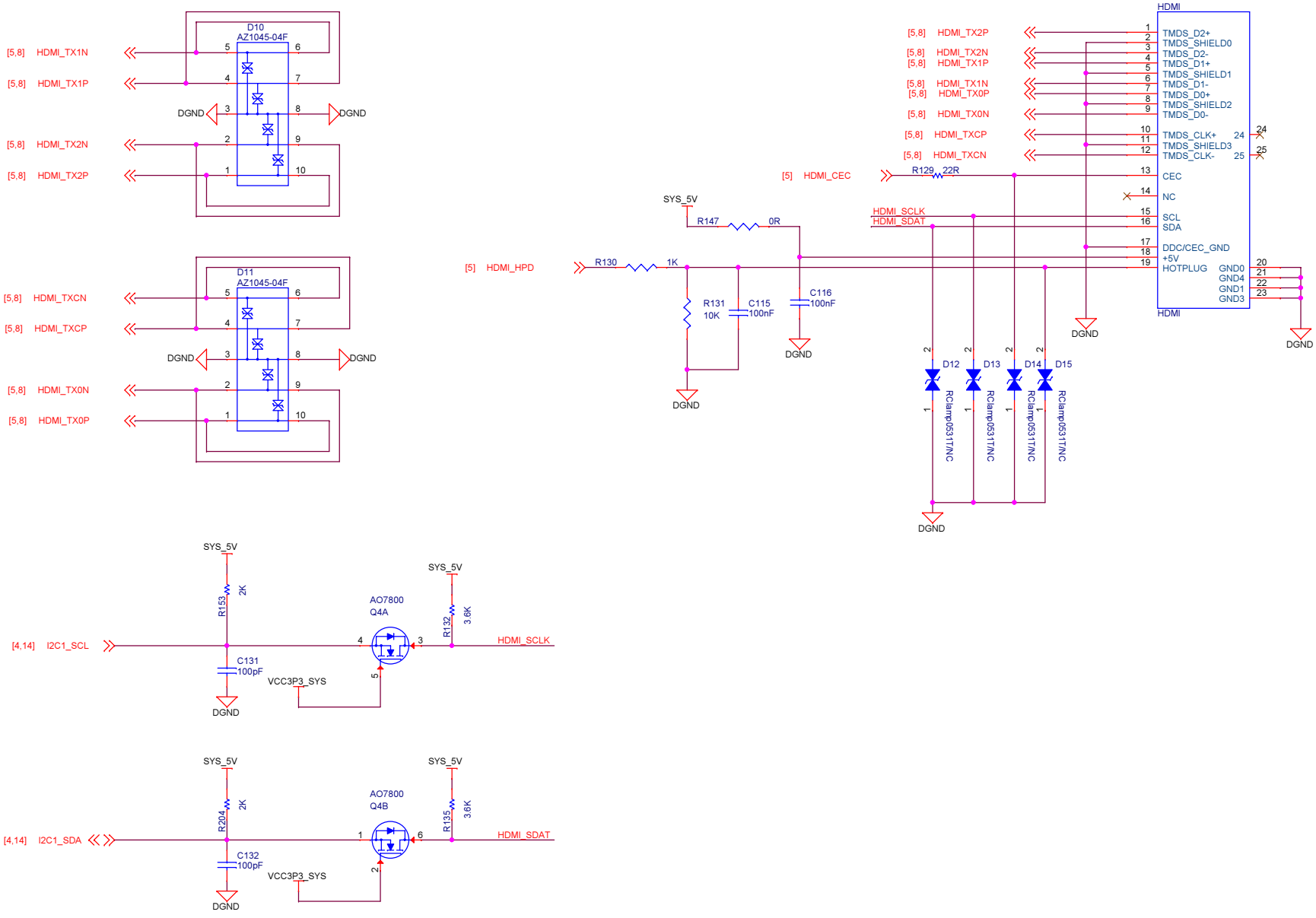

NanoPi M2A/M3		
Size	Document Number	Rev
A3	09.HDMI	1604
Date:	Wednesday, May 18, 2016	Sheet 8 of 15

Audio

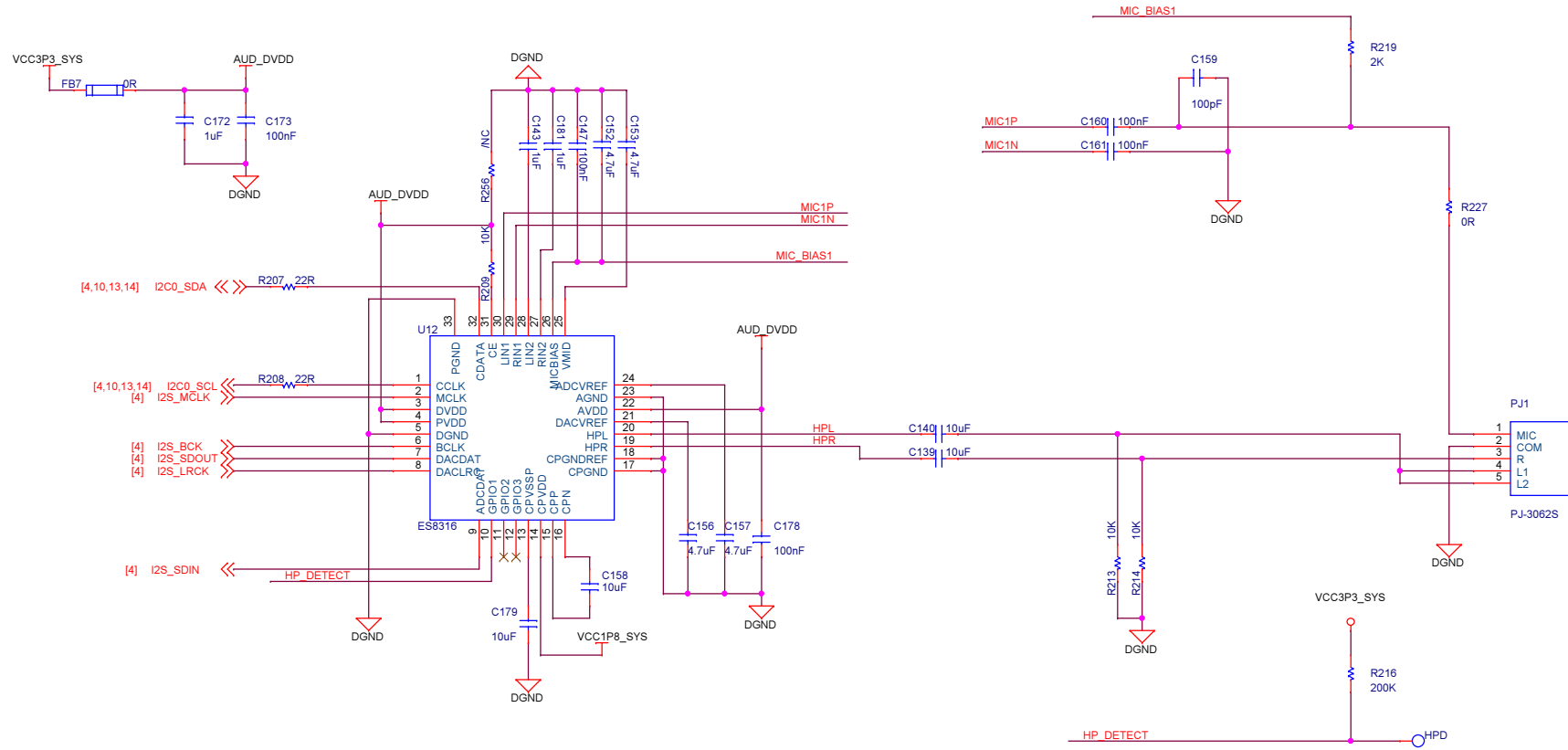

FRIENDLYARM

NanoPi M2AM3		
Size	Document Number	Rev
A3	12.Audio	1604
Date:	Wednesday, May 18, 2016	Sheet 9 of 15

EEPROM with MAC Address

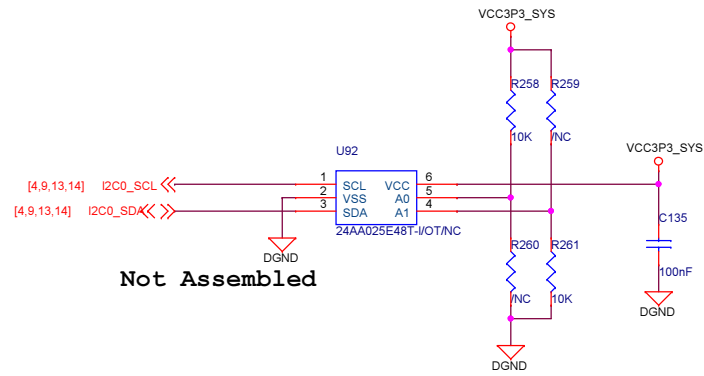

FRIENDLYARM

NanoPi M2AM3		
Size	Document Number	Rev
A3	11.EEPROM, SHA-256, Holes	1604
Date:	Wednesday, May 18, 2016	Sheet 10 of 15

10/100/1000M Ethernet

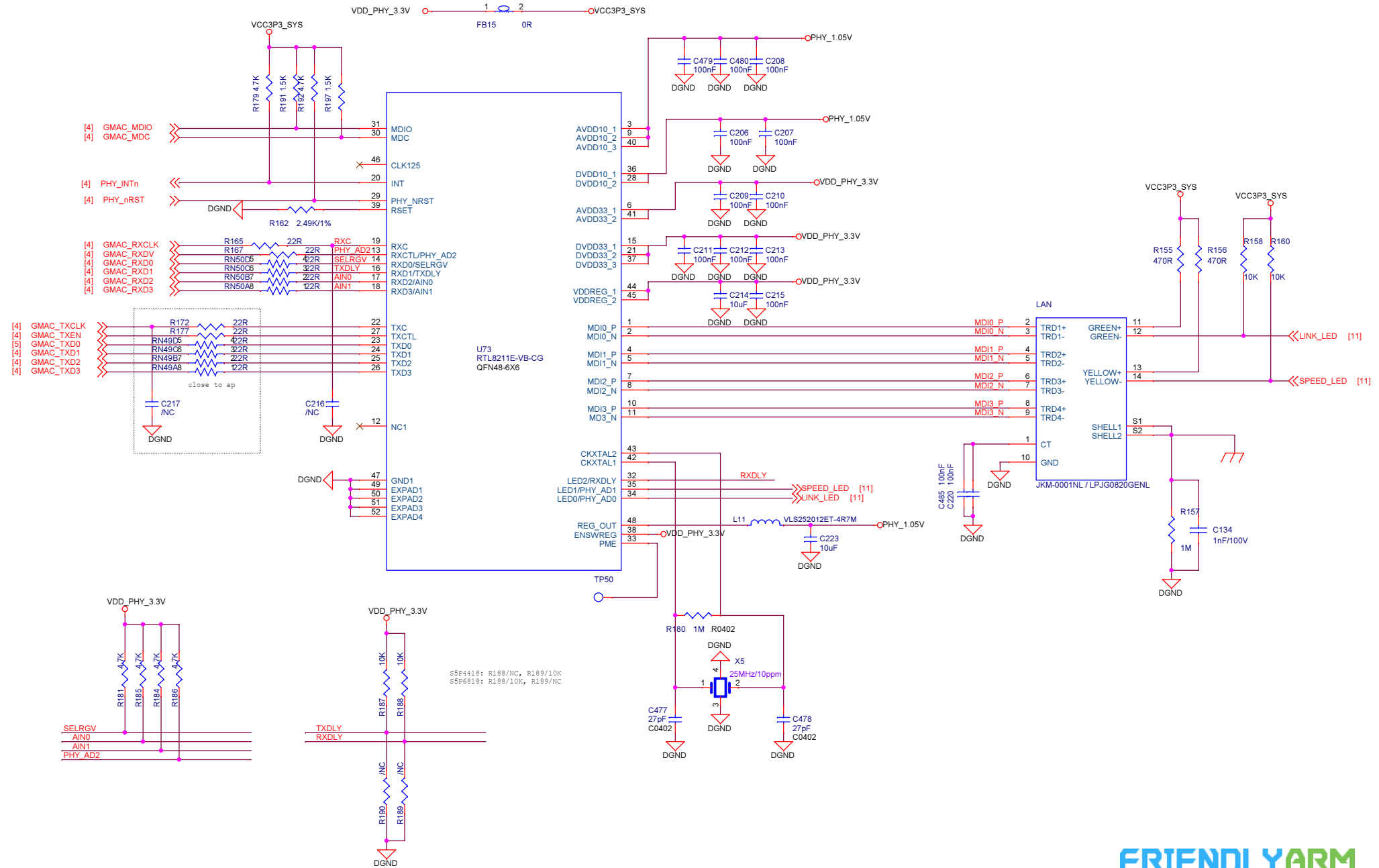

NanoPi M2A/M3		
Size A3	Document Number 14.LAN	Rev 1604
Date: Wednesday, May 18, 2016	Sheet 11	of 15

USB 2.0 Host

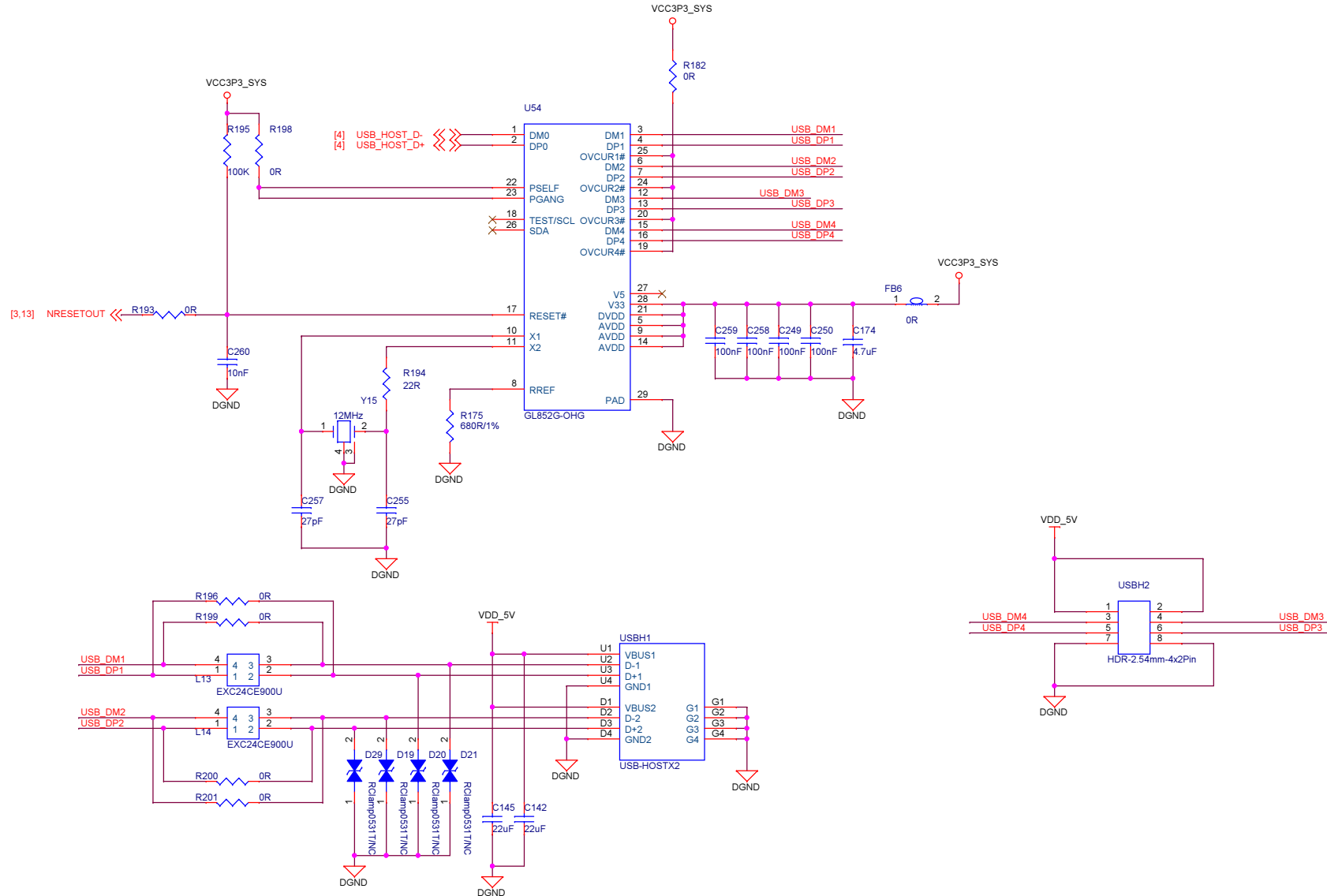

NanoPi M2A/M3		
Size A3	Document Number 15.USB-Host	Rev 1604
Date: Wednesday, May 18, 2016	Sheet 12	of 15

SDCARD

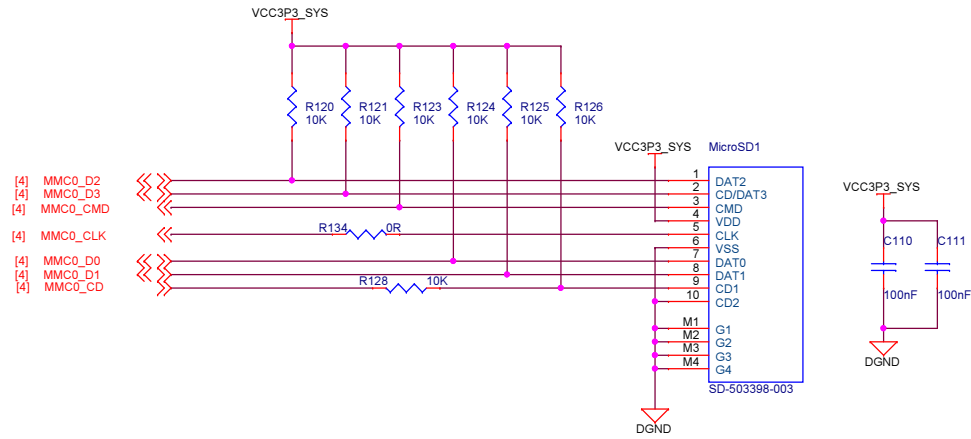

RGB LCD Interface

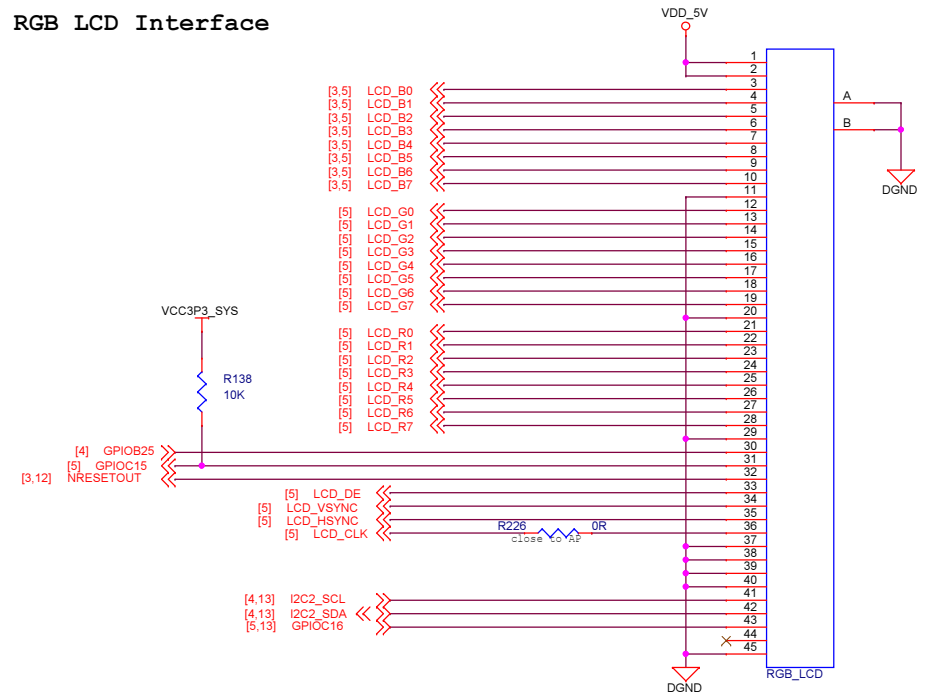

LVDS

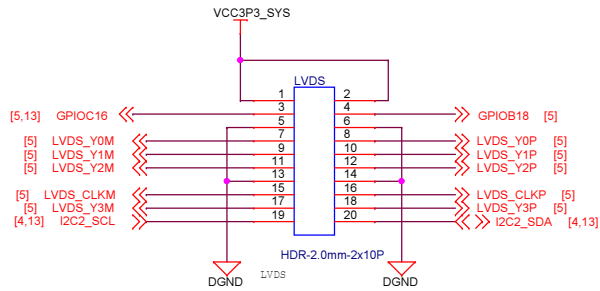

I2S Interface

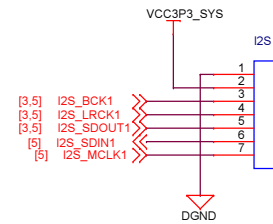

Camera Interface

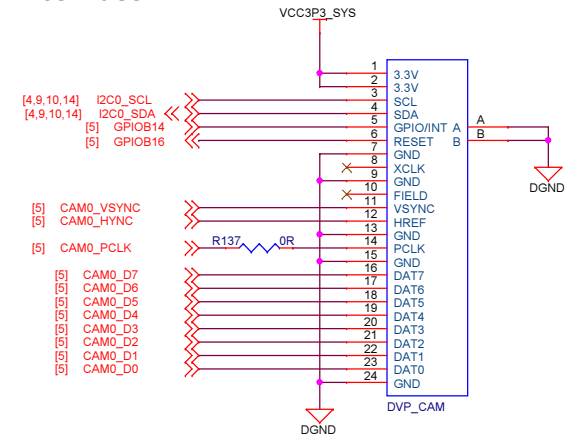

FRIENDLYARM

2.54mm Header

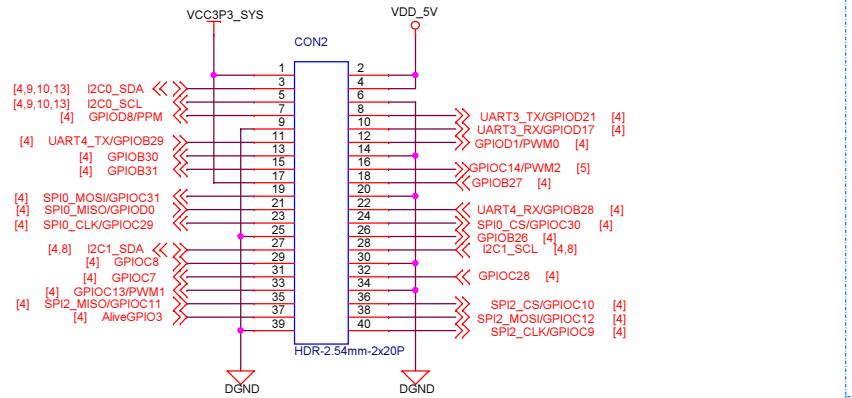

MicroUSB

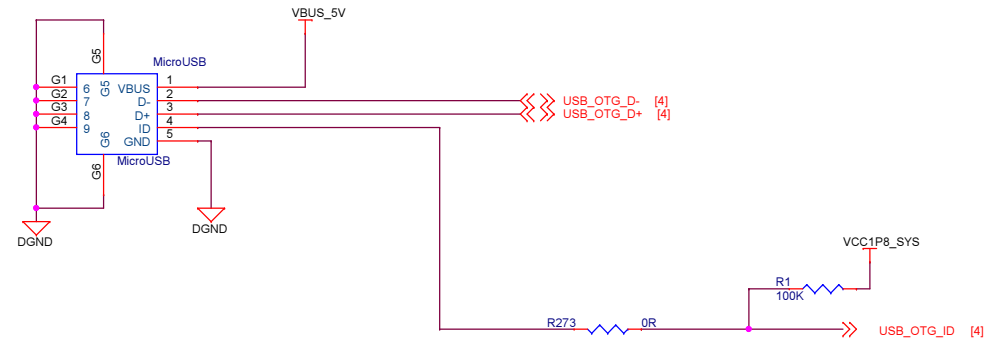

LEDs

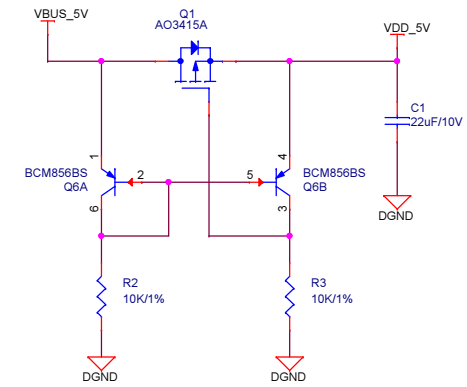
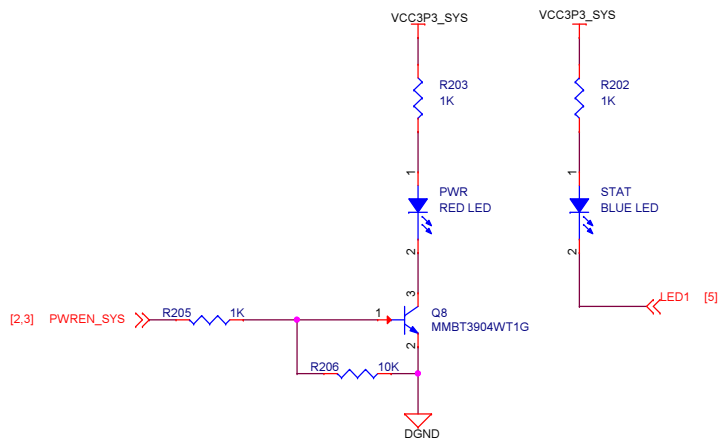

Buttons

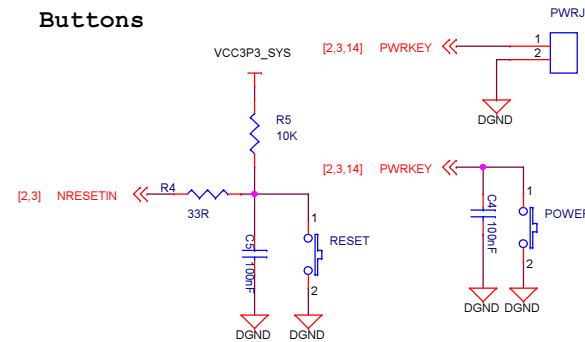

Debug UART

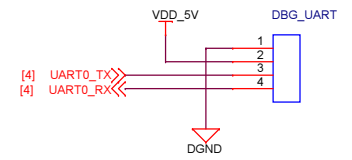

FRIENDLYARM

Wi-Fi/Bluetooth

